

# **Burnside Road West @ Marigold Road**

**Wednesday, October 23, 2019**



The data presented here is for information purposes only and should not be considered authoritative for construction, geotechnical, engineering, navigational, legal, or other site-specific uses. The information shared is owned by the Transportation Division of the Engineering Department at the District of Saanich. Accuracy is not guaranteed.

**Major Route:** Burnside Road West  
**Minor Route:** Marigold Road  
**Municipality:** Saanich  
**Filename:** Burnside Road West @ Marigold Rd-Oct 23, 2019.xlsx  
**Location #:** TIN001304  
**Count ID:** 2019029  
**Date:** October 23, 2019  
**Day-of-week:** Wednesday

**East/West Route:** Burnside Road West  
**Intersection Type:** 3-leg north approach  
**Signalized?:** No  
**Weather:** Overcast and dry

**Vehicle Classifications:** Vehicles and Peds  
 Bikes

**This data is for Vehicles and Peds**

Shift	Start	End	Duration
AM	7:30	9:30	2.00
MD			
PM	15:30	18:30	3.00
<b>Total</b>	<b>7:30</b>	<b>18:30</b>	<b>5.00</b>

**Notes:** 24-hour clock used for reporting (15-minute increments)  
 North Approach - southbound vehicles approaching intersection from the north  
 15x4 - 15 min volume (from maximum 15 minute period of movement/approach in peak hour period [\*]) x 4  
 Pedestrians - N indicates pedestrians crossing north approach (east/west)

**Comments:**







Time Period Begins	Marigold Rd				Burnside Road West				Burnside Road West				Total Volume		Ped	Crosswalks				Conflict					
	NORTH Approach				SOUTH Approach				WEST Approach				EAST Approach				15-min	Hour	N	S	W	E	15 min	Hr	
	Left	Thru	Right	Total	Left	Thru	Right	Total	Left	Thru	Right	Total	Left	Thru		Right									Total
15:30	53		60	113					39	57		96		36	2	38	247	*	8		1	9	137		
15:45	67		81	148					32	56		88		27	5	32	268	*	0		0	12	145		
16:00	67		73	140					27	53		80		37	8	45	265	*	0		0	3	145		
16:15	73		60	133					51	59		110		30	7	37	280	1060+	0		0	4	161	588	
16:30	75		56	131					31	45		76		29	10	39	246	1059	3		0	10	145	596	
16:45	81		61	142					39	57		96		22	6	28	266	1057	17		0	1	148	599	
17:00	86		54	140					32	34		66		32	5	37	243	1035	3		0	8	155	609	
17:15	65		64	129					21	41		62		33	7	40	231	986	0		0	7	126	574	
17:30	54		59	113					28	56		84		33	7	40	237	977	1		0	2	127	556	
17:45	34		42	76					13	31		44		40	9	49	169	880	1		0	2	104	512	
18:00	25		36	61					16	37		53		37	17	54	168	805	2		0	2	106	463	
18:15	22		32	54					15	45		60		44	11	55	169	743	2		0	4	102	439	
n/a																									
n/a																									
n/a																									
n/a																									
n/a																									
n/a																									
n/a																									
n/a																									
n/a																									
n/a																									
n/a																									

Total	702		678	1380					344	571		915		400	94	494	2789			37		1	64	1540
Avg Hr	234		226	460					115	190		305		133	31	165	930			12		0	21	

Peak hour of the intersection

Pk Hr	260		274	534					149	225		374		130	22	152	1060	*		8		1	28	575
15x4	292		324	592					204	236		440		148	32	180	1120	+		32		4	48	708
PHF	0.89		0.85	0.90					0.73	0.95		0.85		0.88	0.69	0.84	0.95			0.25		0.25	0.58	0.81

Peak hour of conflicting volumes for the intersection

Pk Hr	315		231	546					153	195		348		113	28	141	1035	*		23		0	23	609
15x4	344		244	568					204	236		440		128	40	156	1120	+		68		0	40	716
PHF	0.92		0.95	0.96					0.75	0.83		0.79		0.88	0.70	0.90	0.92			0.34		n/a	0.58	0.85

\*\* Calculated peak hour occurs during the first or last hour of shift and therefore may be invalid. \*\* N

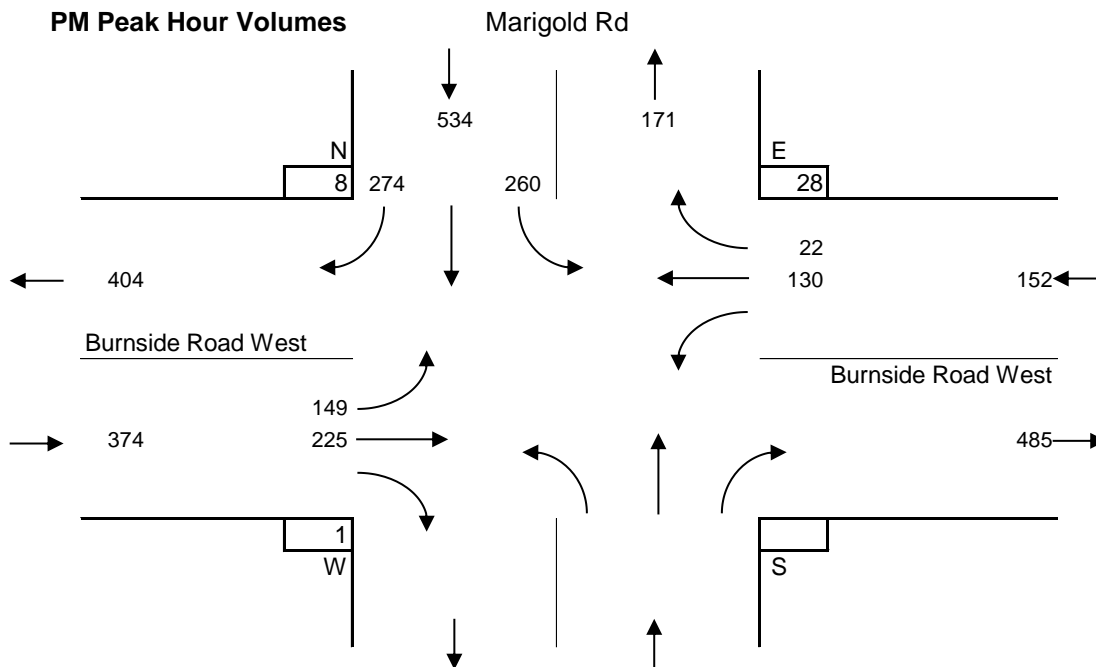

Entire Survey Period

5 Hours

	Marigold Rd				SOUTH Approach				Burnside Road West WEST Approach				Burnside Road West EAST Approach				Total Volume	Crosswalks			
	NORTH Approach				Left	Thru	Right	Total	Left	Thru	Right	Total	Left	Thru	Right	Total		N	S	W	E
	Left	Thru	Right	Total																	
Total	774		963	1737					871	1797		2668		800	181	981	5386	61		2	321
Avg Hr	155		193	347					174	359		534		160	36	196	1077	12		0	64

AM Peak Period

2 Hours

	Marigold Rd				SOUTH Approach				Burnside Road West WEST Approach				Burnside Road West EAST Approach				Total Volume	Crosswalks			
	NORTH Approach				Left	Thru	Right	Total	Left	Thru	Right	Total	Left	Thru	Right	Total		N	S	W	E
	Left	Thru	Right	Total																	
Totals	72		285	357					527	1226		1753		400	87	487	2597	24		1	257
Avg Hr	36		143	179					264	613		877		200	44	244	1299	12		1	129

MD Peak Period

Hours

	Marigold Rd				SOUTH Approach				Burnside Road West WEST Approach				Burnside Road West EAST Approach				Total Volume	Crosswalks			
	NORTH Approach				Left	Thru	Right	Total	Left	Thru	Right	Total	Left	Thru	Right	Total		N	S	W	E
	Left	Thru	Right	Total																	
Total																					
Avg Hr																					

PM Peak Period

3 Hours

	Marigold Rd				SOUTH Approach				Burnside Road West WEST Approach				Burnside Road West EAST Approach				Total Volume	Crosswalks			
	NORTH Approach				Left	Thru	Right	Total	Left	Thru	Right	Total	Left	Thru	Right	Total		N	S	W	E
	Left	Thru	Right	Total																	
Totals	702		678	1380					344	571		915		400	94	494	2789	37		1	64
Avg Hr	234		226	460					115	190		305		133	31	165	930	12		0	21

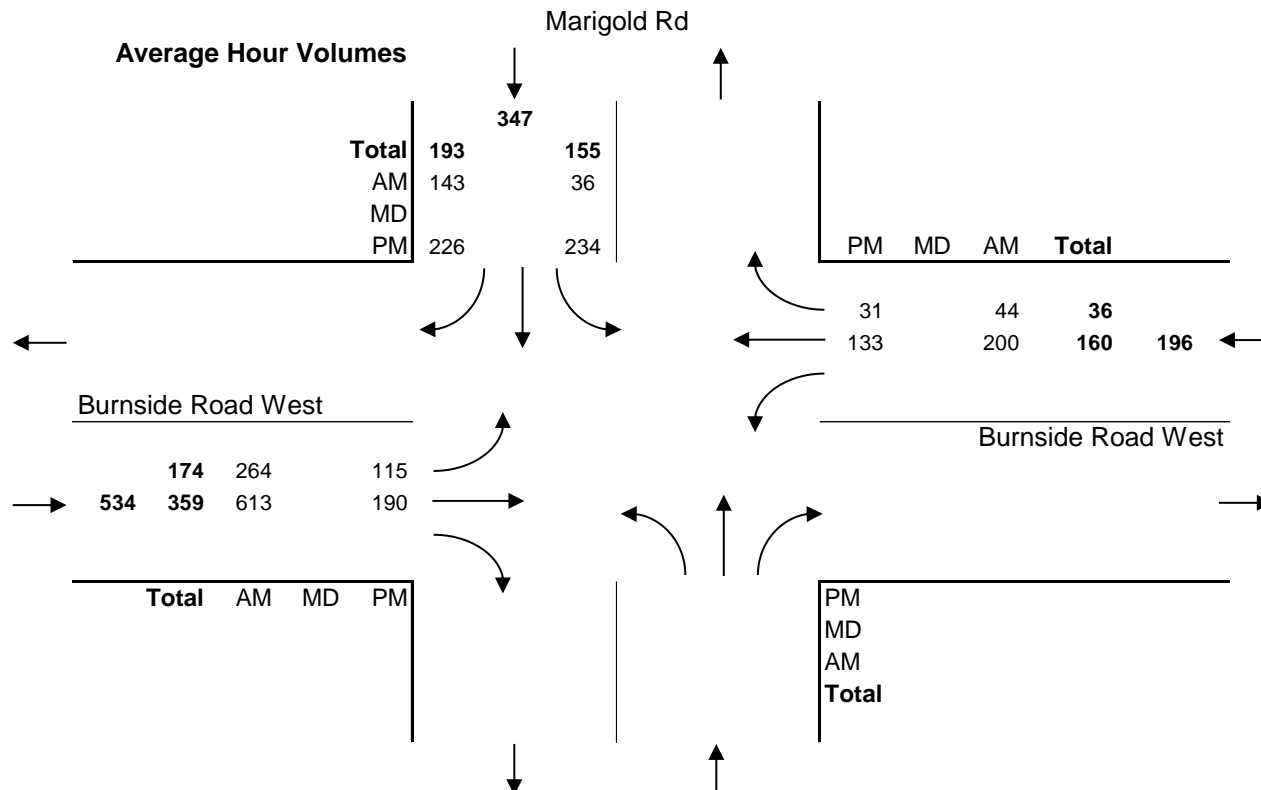

**Major Route:** Burnside Road West  
**Minor Route:** Marigold Road  
**Municipality:** Saanich  
**Filename:** Burnside Road West @ Marigold Rd-Oct 23, 2019.xlsx  
**Location #:** TIN001304  
**Count ID:** 2019029  
**Date:** October 23, 2019  
**Day-of-week:** Wednesday

**East/West Route:** Burnside Road West  
**Intersection Type:** 4-leg  
**Signalized?:** No  
**Weather:** Overcast and dry

**Vehicle Classifications:** Vehicles and Peds      **This data is for Bikes**  
 Bikes

Shift	Start	End	Duration
AM	7:30	9:30	2.00
MD			
PM	15:30	18:30	3.00
<b>Total</b>	<b>7:30</b>	<b>18:30</b>	<b>5.00</b>

**Notes:** 24-hour clock used for reporting (15-minute increments)  
 North Approach - southbound vehicles approaching intersection from the north  
 15x4 - 15 min volume (from maximum 15 minute period of movement/approach in peak hour period [\*]) x 4  
 Pedestrians - N indicates pedestrians crossing north approach (east/west)

**Comments:**



Survey Data  
Bikes

Burnside Road West @ Marigold Road  
Wednesday, October 23, 2019

Time Period Begins	Marigold Rd				Burnside Road West				Burnside Road West				Total Volume		Day								
	NORTH Approach				SOUTH Approach				WEST Approach				EAST Approach				15-min	Hour	N	S	W	E	
	Left	Thru	Right	Total	Left	Thru	Right	Total	Left	Thru	Right	Total	Left	Thru		Right							Total
7:30	0	0	1	1	0	0	0	0	0	3	0	3	0	0	0	0	4	*	0	0	0	0	
7:45	0	0	1	1	0	0	0	0	0	4	0	4	0	1	0	1	6	+	0	0	0	0	
8:00	0	0	1	1	0	0	0	0	1	2	0	3	0	2	0	2	6	*	0	0	0	0	
8:15	0	0	0	0	0	0	0	0	0	2	0	2	0	1	0	1	3	19*	0	0	0	0	
8:30	0	0	0	0	0	0	0	0	0	2	0	2	0	2	0	2	4	19	0	0	0	0	
8:45	0	0	0	0	0	0	0	0	0	4	0	4	0	0	0	0	4	17	0	0	0	0	
9:00	0	0	0	0	0	0	0	0	0	3	0	3	0	0	0	0	3	14	0	0	0	0	
9:15	0	0	0	0	0	0	0	0	0	2	0	2	0	2	0	2	4	15	0	0	0	0	
n/a																							
n/a																							
n/a																							
n/a																							
n/a																							
n/a																							
n/a																							
n/a																							
n/a																							
n/a																							
n/a																							
n/a																							
Total	0	0	3	3	0	0	0	0	1	22	0	23	0	8	0	8	34		0	0	0	0	

n/a																						
n/a																						
n/a																						
n/a																						
n/a																						
n/a																						
n/a																						
n/a																						
n/a																						
n/a																						
n/a																						
n/a																						
n/a																						
n/a																						
n/a																						
Total																						

15:30	0	0	0	0	0	0	0	0	0	3	0	3	0	0	0	0	3			0	0	0	0
15:45	0	0	0	0	0	0	0	0	0	1	0	1	0	3	0	3	4			0	0	0	0
16:00	0	0	0	0	0	0	0	0	0	1	0	1	0	0	0	0	1			0	0	0	0
16:15	0	0	0	0	0	0	0	0	3	4	0	7	0	1	1	2	9	17	+	0	0	0	0
16:30	0	0	0	0	0	0	0	0	3	1	0	4	0	1	1	2	6	20	*	0	0	0	0
16:45	0	0	1	1	0	0	0	0	2	1	0	3	0	3	1	4	8	24	*	0	0	0	0
17:00	1	0	0	1	0	0	0	0	0	4	0	4	0	1	0	1	6	29	*	0	0	0	0
17:15	0	0	0	0	0	0	0	0	0	0	0	0	0	2	0	2	2	22		0	0	0	0
17:30	0	0	0	0	0	0	0	0	0	0	0	0	0	0	1	1	1	17		0	0	0	0
17:45	0	0	1	1	0	0	0	0	1	1	0	2	0	0	0	0	3	12		0	0	0	0
18:00	0	0	1	1	0	0	0	0	0	0	0	0	0	2	0	2	3	9		0	0	0	0
18:15	0	0	1	1	0	0	0	0	1	1	0	2	0	1	0	1	4	11		0	0	0	0
n/a																							
n/a																							
n/a																							
n/a																							
n/a																							
n/a																							
n/a																							
n/a																							
Total	1	0	4	5	0	0	0	0	10	17	0	27	0	14	4	18	50			0	0	0	0

Time Period Begins	Marigold Rd				Burnside Road West				Burnside Road West				Total Volume		Days of Week	Conflict								
	NORTH Approach				SOUTH Approach				WEST Approach				EAST Approach				15-min	Hour	N	S	W	E	15 min	Hr
7:30	0	0	1	1	0	0	0	0	0	3	0	3	0	0	0	0	4	*	0	0	0	0	4	
7:45	0	0	1	1	0	0	0	0	0	4	0	4	0	1	0	1	6	+	0	0	0	0	5	
8:00	0	0	1	1	0	0	0	0	1	2	0	3	0	2	0	2	6	*	0	0	0	0	4	
8:15	0	0	0	0	0	0	0	0	0	2	0	2	0	1	0	1	3	19*	0	0	0	0	2	15
8:30	0	0	0	0	0	0	0	0	0	2	0	2	0	2	0	2	4	19	0	0	0	0	2	13
8:45	0	0	0	0	0	0	0	0	0	4	0	4	0	0	0	0	4	17	0	0	0	0	4	12
9:00	0	0	0	0	0	0	0	0	0	3	0	3	0	0	0	0	3	14	0	0	0	0	3	11
9:15	0	0	0	0	0	0	0	0	0	2	0	2	0	2	0	2	4	15	0	0	0	0	2	11
n/a																								
n/a																								
n/a																								
n/a																								
n/a																								
n/a																								
n/a																								
n/a																								
n/a																								
n/a																								
n/a																								

Total	0	0	3	3	0	0	0	0	1	22	0	23	0	8	0	8	34							
Avg Hr	0	0	2	2	0	0	0	0	1	11	0	12	0	4	0	4	17							

0	0	0	0	25
0	0	0	0	

Peak hour of the intersection

Pk Hr	0	0	3	3	0	0	0	0	1	11	0	12	0	4	0	4	19	*						
15x4	0	0	4	4	0	0	0	0	4	16	0	16	0	8	0	8	24	+						
PHF	n/a	n/a	0.75	0.75	n/a	n/a	n/a	n/a	0.25	0.69	n/a	0.75	n/a	0.50	n/a	0.50	0.79							

0	0	0	0	14
0	0	0	0	20
n/a	n/a	n/a	n/a	0.70

Peak hour of conflicting volumes for the intersection

Pk Hr	0	0	3	3	0	0	0	0	1	11	0	12	0	4	0	4	19	*						
15x4	0	0	4	4	0	0	0	0	4	16	0	16	0	8	0	8	24	+						
PHF	n/a	n/a	0.75	0.75	n/a	n/a	n/a	n/a	0.25	0.69	n/a	0.75	n/a	0.50	n/a	0.50	0.79							

0	0	0	0	14
0	0	0	0	20
n/a	n/a	n/a	n/a	0.70

\*\* Calculated peak hour occurs during the first or last hour of shift and therefore may be invalid. \*\*

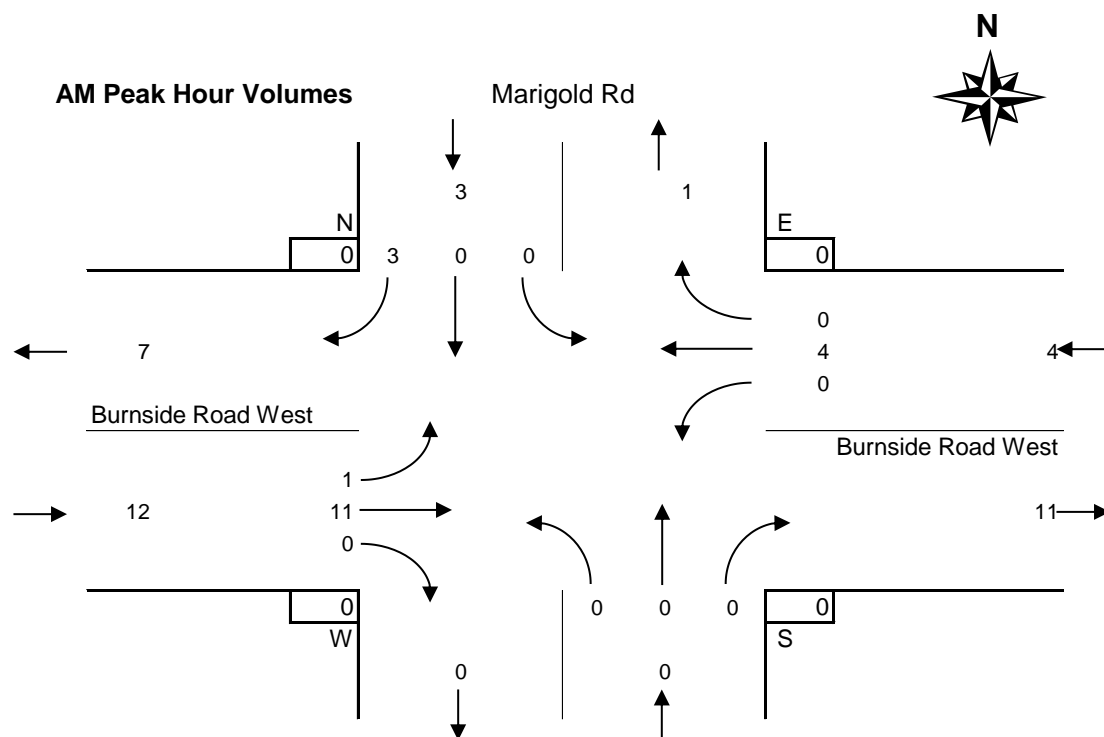

MD Peak Period  
Bikes

**Burnside Road West @ Marigold Road**  
Wednesday, October 23, 2019

Time Period Begins	Marigold Rd				Burnside Road West				Burnside Road West				Total Volume		Road ID	Conflict								
	NORTH Approach				SOUTH Approach				WEST Approach				EAST Approach				15-min	Hour	N	S	W	E	15 min	Hr
	Left	Thru	Right	Total	Left	Thru	Right	Total	Left	Thru	Right	Total	Left	Thru	Right	Total	15-min	Hour						
n/a																								
n/a																								
n/a																								
n/a																								
n/a																								
n/a																								
n/a																								
n/a																								
n/a																								
n/a																								
n/a																								
n/a																								
n/a																								
n/a																								
n/a																								
n/a																								
n/a																								
n/a																								
n/a																								
n/a																								
n/a																								

Total																										
Avg Hr																										

**Peak hour of the intersection**

Pk Hr																										
15x4																										
PHF																										

**Peak hour of conflicting volumes for the intersection**

Pk Hr																										
15x4																										
PHF																										

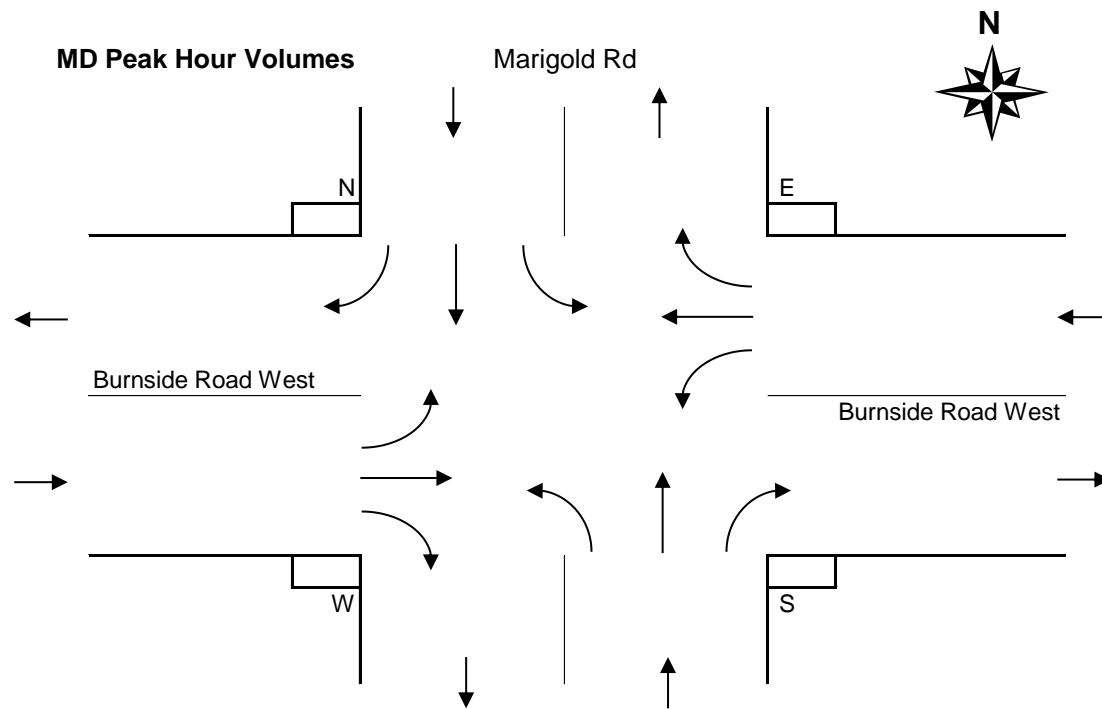

Time Period Begins	Marigold Rd NORTH Approach				Marigold Rd SOUTH Approach				Burnside Road West WEST Approach				Burnside Road West EAST Approach				Total Volume		Yield	Conflict					
	Left	Thru	Right	Total	Left	Thru	Right	Total	Left	Thru	Right	Total	Left	Thru	Right	Total	15-min	Hour		N	S	W	E	15 min	Hr
	15:30	0	0	0	0	0	0	0	0	0	3	0	3	0	0	0	0	3			0	0	0	0	3
15:45	0	0	0	0	0	0	0	0	0	1	0	1	0	3	0	3	4		0	0	0	0	3		
16:00	0	0	0	0	0	0	0	0	0	1	0	1	0	0	0	0	1		0	0	0	0	1		
16:15	0	0	0	0	0	0	0	0	3	4	0	7	0	1	1	2	9	17	+	0	0	0	0	5	12
16:30	0	0	0	0	0	0	0	0	3	1	0	4	0	1	1	2	6	20	*	0	0	0	0	5	14
16:45	0	0	1	1	0	0	0	0	2	1	0	3	0	3	1	4	8	24	*	0	0	0	0	7	18
17:00	1	0	0	1	0	0	0	0	0	4	0	4	0	1	0	1	6	29	*	0	0	0	0	5	22
17:15	0	0	0	0	0	0	0	0	0	0	0	0	0	2	0	2	2	22		0	0	0	0	2	19
17:30	0	0	0	0	0	0	0	0	0	0	0	0	0	0	1	1	1	17		0	0	0	0	1	15
17:45	0	0	1	1	0	0	0	0	1	1	0	2	0	0	0	0	3	12		0	0	0	0	2	10
18:00	0	0	1	1	0	0	0	0	0	0	0	0	0	2	0	2	3	9		0	0	0	0	3	8
18:15	0	0	1	1	0	0	0	0	1	1	0	2	0	1	0	1	4	11		0	0	0	0	3	9
n/a																									
n/a																									
n/a																									
n/a																									
n/a																									
n/a																									
n/a																									
n/a																									
n/a																									
n/a																									
n/a																									
n/a																									
<b>Total</b>	1	0	4	5	0	0	0	0	10	17	0	27	0	14	4	18	50			0	0	0	0		32
<b>Avg Hr</b>	0	0	1	2	0	0	0	0	3	6	0	9	0	5	1	6	17			0	0	0	0		

**Peak hour of the intersection**

Pk Hr	Left	Thru	Right	Total	Left	Thru	Right	Total	Left	Thru	Right	Total	Left	Thru	Right	Total	PHF	15-min	Hour	N	S	W	E	15 min	Hr
15:30-18:15	1	0	1	2	0	0	0	0	8	10	0	18	0	6	3	9	0.25	n/a	0.25	0	0	0	0	18	
15x4	4	0	4	4	0	0	0	0	12	16	0	28	0	12	4	16	0.25			0	0	0	0	32	
PHF	0.25	n/a	0.25	<b>0.50</b>	n/a	n/a	n/a	<b>n/a</b>	0.67	0.63	n/a	<b>0.64</b>	n/a	0.50	0.75	<b>0.56</b>				n/a	n/a	n/a	n/a	0.56	

**Peak hour of conflicting volumes for the intersection**

Pk Hr	Left	Thru	Right	Total	Left	Thru	Right	Total	Left	Thru	Right	Total	Left	Thru	Right	Total	PHF	15-min	Hour	N	S	W	E	15 min	Hr
15:30-18:15	1	0	1	2	0	0	0	0	8	10	0	18	0	6	3	9	0.25	n/a	0.25	0	0	0	0	18	
15x4	4	0	4	4	0	0	0	0	12	16	0	28	0	12	4	16	0.25			0	0	0	0	32	
PHF	0.25	n/a	0.25	<b>0.50</b>	n/a	n/a	n/a	<b>n/a</b>	0.67	0.63	n/a	<b>0.64</b>	n/a	0.50	0.75	<b>0.56</b>				n/a	n/a	n/a	n/a	0.56	

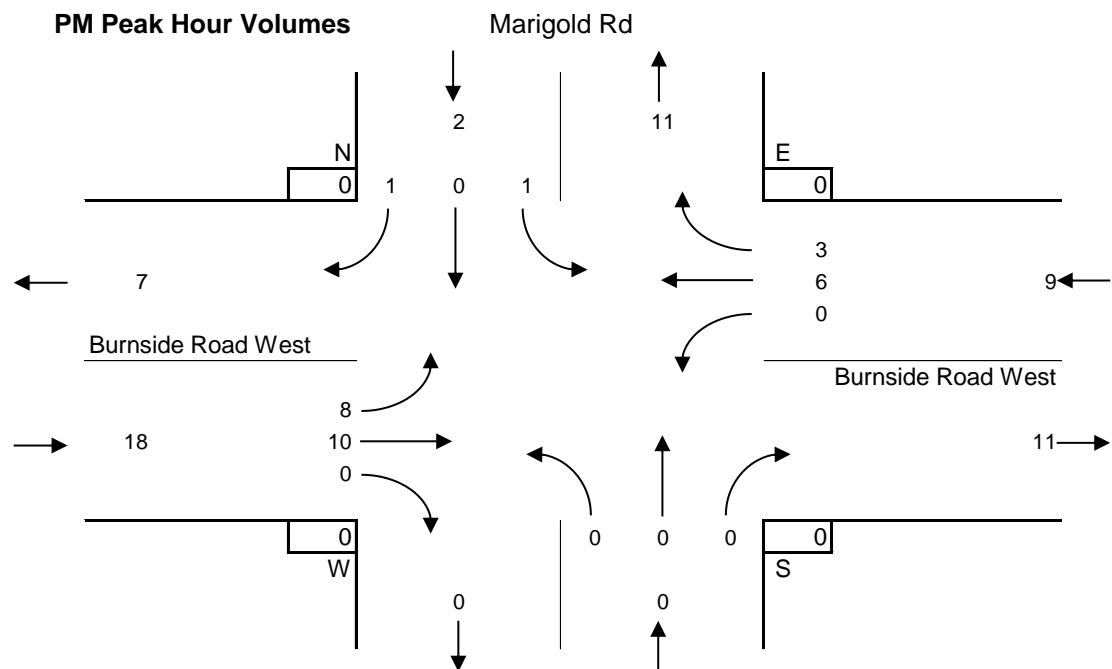

Entire Survey Period

5 Hours

	Marigold Rd				SOUTH Approach				WEST Approach				EAST Approach				Total Volume					
	NORTH Approach				Left	Thru	Right	Total	Left	Thru	Right	Total	Left	Thru	Right	Total		Volume	N	S	W	E
	Left	Thru	Right	Total																		
Total	1	0	7	8	0	0	0	0	11	39	0	50	0	22	4	26	84	0	0	0	0	
Avg Hr	0	0	1	2	0	0	0	0	2	8	0	10	0	4	1	5	17	0	0	0	0	

AM Peak Period

2 Hours

	Marigold Rd				SOUTH Approach				WEST Approach				EAST Approach				Total Volume					
	NORTH Approach				Left	Thru	Right	Total	Left	Thru	Right	Total	Left	Thru	Right	Total		Volume	N	S	W	E
	Left	Thru	Right	Total																		
Totals	0	0	3	3	0	0	0	0	1	22	0	23	0	8	0	8	34	0	0	0	0	
Avg Hr	0	0	2	2	0	0	0	0	1	11	0	12	0	4	0	4	17	0	0	0	0	

MD Peak Period

Hours

	Marigold Rd				SOUTH Approach				WEST Approach				EAST Approach				Total Volume					
	NORTH Approach				Left	Thru	Right	Total	Left	Thru	Right	Total	Left	Thru	Right	Total		Volume	N	S	W	E
	Left	Thru	Right	Total																		
Totals																						
Total																						
Avg Hr																						

PM Peak Period

3 Hours

	Marigold Rd				SOUTH Approach				WEST Approach				EAST Approach				Total Volume					
	NORTH Approach				Left	Thru	Right	Total	Left	Thru	Right	Total	Left	Thru	Right	Total		Volume	N	S	W	E
	Left	Thru	Right	Total																		
Totals	1	0	4	5	0	0	0	0	10	17	0	27	0	14	4	18	50	0	0	0	0	
Avg Hr	0	0	1	2	0	0	0	0	3	6	0	9	0	5	1	6	17	0	0	0	0	

